

DEMARKO MILITARY VEHICLES

ST 775-24W.H-PA
2023



We are
ready
for any
mission



We are a family business. We've come a long way from a small workshop in Świętochłowice to production plants of over 20 000 m². We have become a strong, stable and truly recognizable European brand.

We handle every project individually. Our customers always receive professional support and technical advice. They are provided by dedicated project managers and expert staff. We build lasting relationships with our Clients based on full trust. We provide them with stability, calm and safety. Once they share their needs with us, we want them to know we'll take care of the rest.

We know our job and we can do it well.

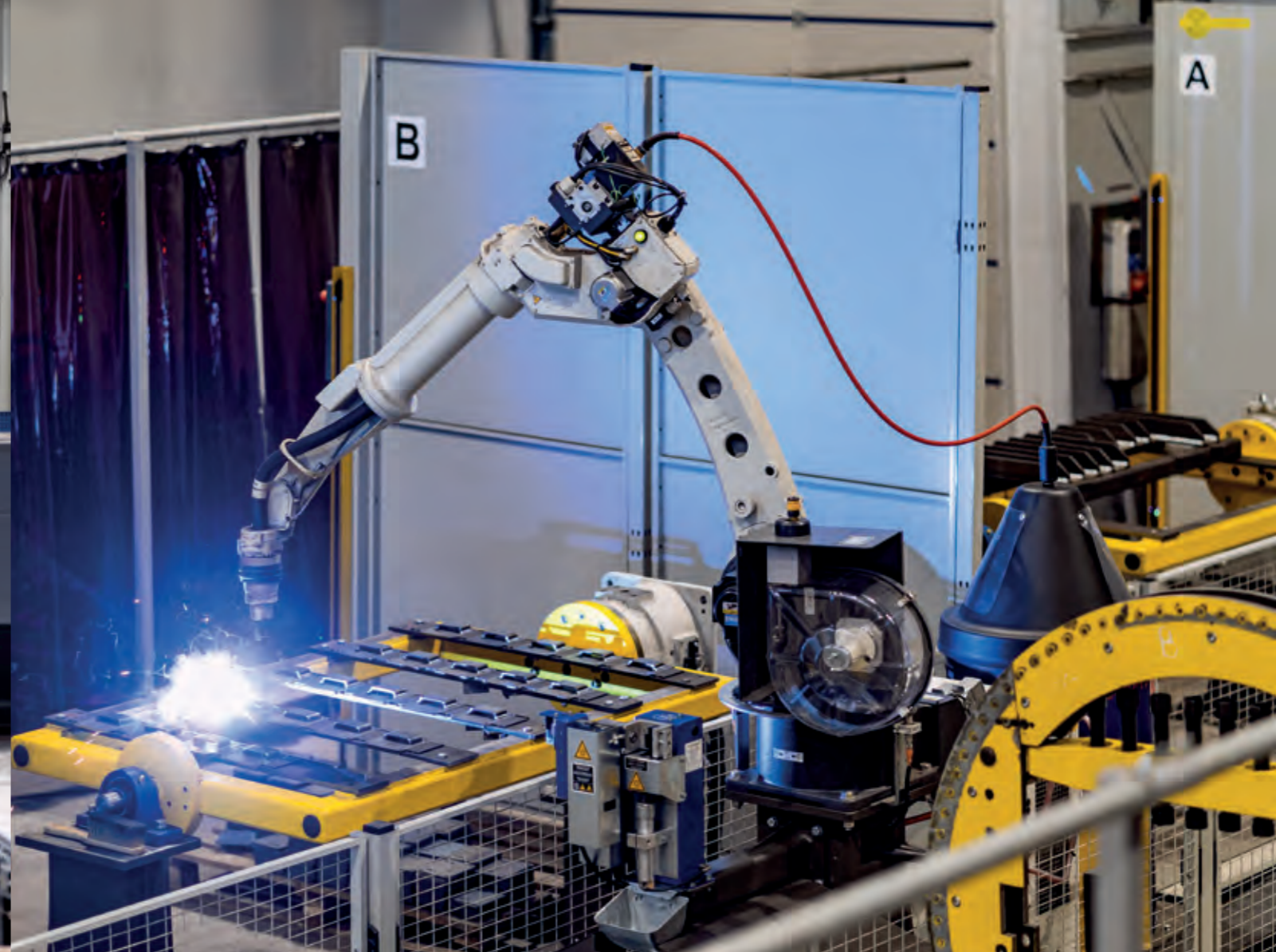

Modern production solutions

We rely on optimized production processes, state-of-the-art technology and highly qualified employees. Our constantly expanding machine park currently consists of over 40 modern CNC machines. Such a rich equipment and technological background, as well as the systematic retrofitting of production stations with tools and control equipment, set the highest standards to guarantee the End User an excellent quality of our vehicles.

Tailor-made solutions

Our experience, flexibility and well-established technical expertise allow us to offer solutions perfectly suited to any transportation task. Knowledge and expertise – from design to production, from the beginning to the end. We will provide you with the best solution tailored to your transportation task.

Automation and robotization

The degree of automation and robotization are key determinants of the production process innovativeness. Complementing each other, they provide us with the possibility of faster, more accurate and safer production processes as well as cost optimization. The cooperation of machines with automation and software is a key element that gives employees the ability to focus on their core tasks, and guarantees clients reliable *just-in-time* deliveries.

Industry and artificial intelligence

Internet of Things (IoT) everything communicates with everything. It's an in-depth digital transformation and automation of production processes, covering the entire supply chain: from placing an order and delivering components for ongoing production, to shipping the goods to clients and after-sales services. The intelligent process control network contributes to significant process optimization and provides access to practically every useful information about the production process at any time and from any place. By implementing artificial intelligence solutions, we have the ability to increase the production efficiency while reducing its costs, thus we are able to respond flexibly to clients' needs.

**1
DESIGN**

Developed from scratch, the specialized steel construction of the semi-trailer, where the main determinant was superior rigidity that ensures perfect operation on paved roads as well as in heavy terrain.

**2
RAMPS**

Fully hydraulically controlled ramps with adjustable spacing.

**3
SUSPENSION**

Independent hydraulic suspension with a stroke of 650 mm with a maximum lateral tilt of up to 25°.

**4
DECK**

Innovative patented deck with a variable width in the range of 3 000 mm – 3 500 mm.

**5
GOOSE NECK**

Stepless adjustment of coupling height in the range of 1 250 mm – 1 650 mm, additionally equipped with load compensation.

**6
HYDRAULIC SYSTEM**

Thanks to the proprietary DIST™ (Demarko Independent Suspension) system, the semi-trailer is suitable to all road conditions.



Demarko Independent Suspension™

Tactical mobility at the highest level. Inclinometers, accelerometers, encoders, independently mounted, rotating, swinging, hydraulically suspended. Suspension stroke of up to 650 mm.

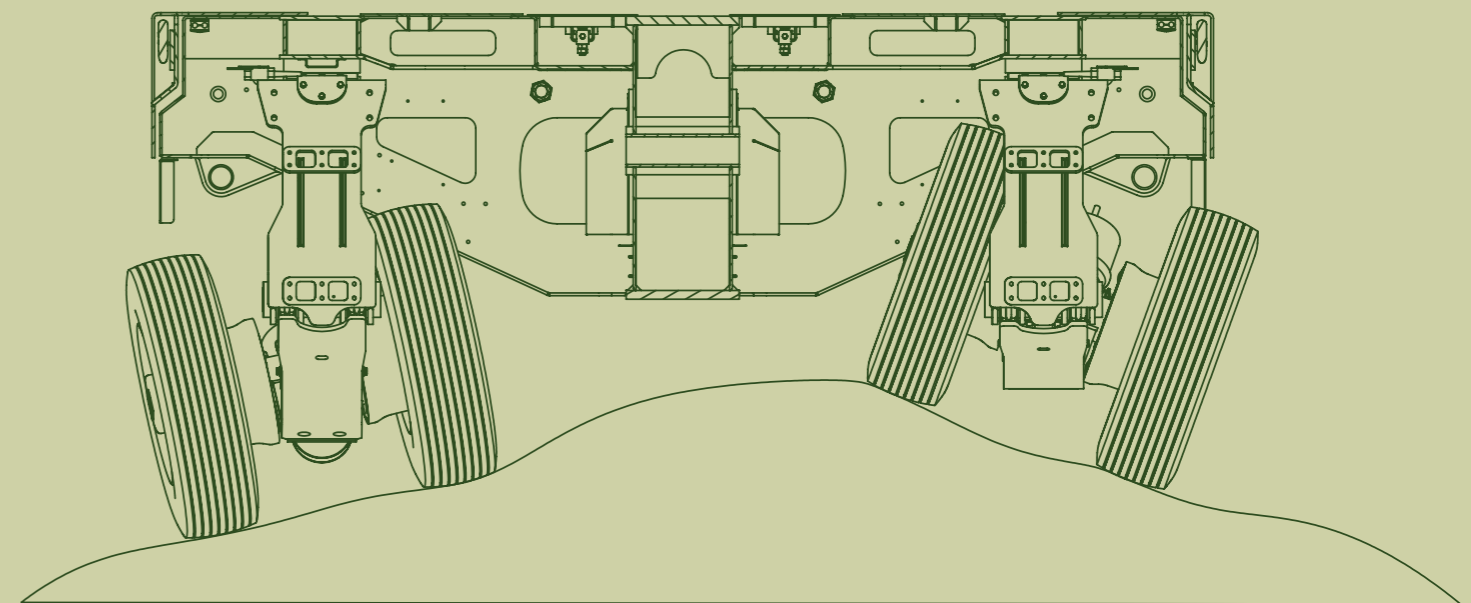
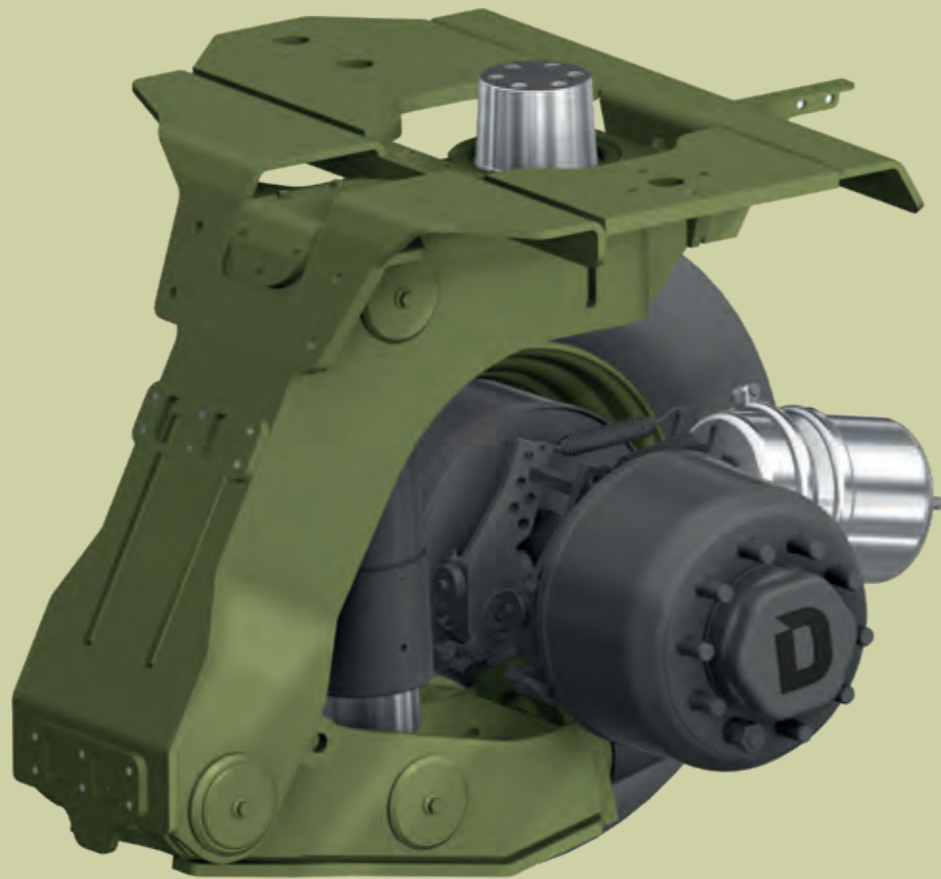

- Variable semi-trailer width, adjustable steplessly, hydraulically controlled. The base width is 3 000 mm. When widened, its value increases to 3 500 mm.
- Nearly perfect kinematics.
- Maximum platform stabilization – the suspension compensates for every tilt.

The coupling height is adjusted hydraulically from 1 250 to 1 650 mm. Load compensation is also possible with a swan neck. Radio control of all trailer functions, variable steering characteristics, adaptive suspension damping, and two independent axle steering circuits, making both counter-rotating and co-rotating turns possible. Automatic wheel calibration.

Demarko
Independent
Suspension™



ST 775-24W.H-PA 2023

DIMENSIONS

TL	Total length	16 382 mm
W	Width	3 000 mm (ex. 3 500 mm)
KH	Coupling height	1 650 mm
LH	Load deck height	1 100 mm / 1 250 mm
LL	Lower load deck length	11 460 mm
UL	Upper load deck length	4 368 mm
FO	Front overhang	670 mm
RO	Rear overhang	1 294 mm
RT	Tractor turning radius	3 030 mm
RA	Semi-trailer turning radius	1 205 mm
AD	Wheelbase	1 500 mm
KA	Distance from king pin to 1 st axle	4 865 mm

WEIGHTS

Gross vehicle weight	96 500 kg
Semi-trailer weight	26 500 kg
Permissible payload	70 000 kg

LOADS

Maximum 5 th wheel load	24 000 kg
Axle load	7 x 12 000 kg

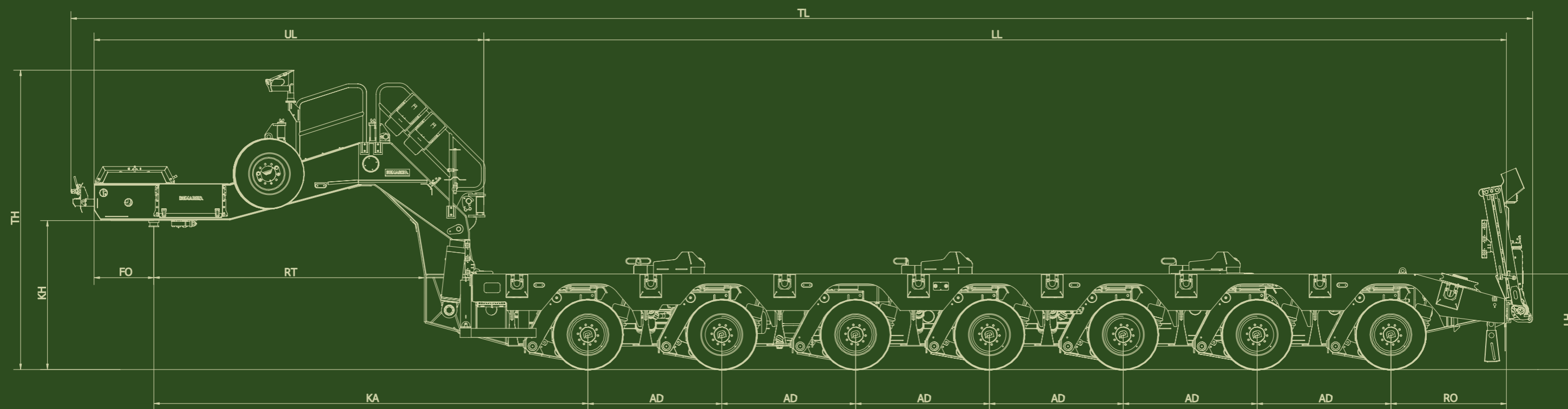



Safety in accordance with MIL-STD-1472F



Perfect cooperation of rigid steel structure with independent hydraulic suspension.



Additional safeguard for transporting wheeled vehicles.



Load fixtures with a force of 20 000 daN

Installations with ergonomic inspection access.





Service available 24 hours a day

We are always ready to help!

User is the most important for us! We offer continuous support. Our qualified employees speak several languages and have the latest technical knowledge in mechanics, electrics, hydraulics and pneumatics.

In addition, our 24-hour service includes mechanics with fully equipped vehicles, available on call at any time. They go wherever the User currently needs help. In this way, we can solve even the most difficult problems on the spot.



34

years of experience
in the automotive industry

40

engineers

200

employees

12

export countries

12000 67%

specialized vehicles
delivered

clients by
recommendation

200000m²

of production area

Cooperation:



Politechnika
Śląska



We hold the following certificates:

ISO 9001:2015, 3834-2

AQAP 2110:2016

LICENCE B-071/2018

NCAGE 99NMH

WSK 1334/W/2021



AQAP 2110:2016
PN-EN ISO 9001:2015



ID 9000001681

We are
at your
disposal

DEMARKO
Spółka Akcyjna

HEADQUARTER
& PRODUCTION FACILITY
ul. Sądowa 19
PL 41-605 Świętochłowice

PRODUCTION FACILITY BYTOM
ul. Kolonia Zygmunt 27, 31 B-C,
PL 41-909 Bytom

Tel. +48 32 770 01 12
Fax. +48 32 706 90 96
info@demarko-military.com

demarko-military.com



